

INSTALLATION / SERVICE / USER MANUAL



INVERTERJET ULTRA 120-150 SERIES

99071 (4) 24/02/2023, Subject to Modification.

MODEL	GAS	MAIN CODE	CLASS
INVERTERJET ULTRA 120	NG	91413	MODULATING PRE-MIX BURNER
	LPG	91433	MODULATING PRE-MIX BURNER
INVERTERJET ULTRA 150	NG	91415	MODULATING PRE-MIX BURNER
	LPG	91435	MODULATING PRE-MIX BURNER

Content

1	Declaration	3
2	Technical Information	6
2.1	Burner Identification and Selection	6
2.2	Burner Identification and Selection	7
2.3	Burner dimensions and weight (Pilot: Optional)	7
2.4	Burner dimensions and weight (No pilot).....	8
2.5	Firing rate.....	8
2.6	Technical Data.....	9
2.7	Description of the Burner Parts (Pilot: optional)	9
2.8	Technical Description of the Burner Parts (No Pilot)	10
2.9	Packaging and transportation	11
2.10	Burner operation.....	12
2.10.1	Heat demand.....	12
2.10.2	Basic sequence of operation.....	12
2.10.2.1	Stand-by.....	12
2.10.2.2	Start-up	12
2.10.2.3	Ignition Sequence	12
2.10.2.4	Run Position.....	12
3	Installation	13
3.1	General Installation Information.....	13
3.2	Handling.....	14
3.3	Burner Mounting.....	14
3.3.1	Standard Burner Mounting Detail.....	14
3.4	Gas Installation	15
3.4.1	Gas train	15
3.4.2	Gas leak test.....	16
3.5	Electrical Installation.....	17
3.5.1	Basic Electrical Safety	17
3.5.2	Burner Wiring Diagrams – Inverterjet Ultra 120-150 (With Pilot).....	18
3.5.3	Burner Wiring Diagrams – Inverterjet Ultra 120-150 (No Pilot).....	19
4	Commissioning	21
4.1	Commissioning procedure.....	21
5	Throttle adjustment screw.....	21
4.1.1	Turning on the Burner	22
4.1.2	Commissioning operation.....	22
4.1.2.1	Maximum rate CO ₂	22
4.1.2.2	Minimum rate CO ₂	22
4.1.2.3	Burner Heat Input.....	22
4.1.2.4	CO ₂ Adjustment Table (Quick Reference).....	23
4.1.2.5	Measured records.....	24
4.1.3	Service Mode.....	24
4.1.3.1	PC USB Interface	24
5	User Instructions	25
5.1	Limitations on use of Burner	25
5.2	Using the Burner	26
5.2.1	Turn Burner On.....	26
5.2.2	Turn Burner Off.....	26
6	Servicing	27
6.1	Service Intervals and personnel	27
6.2	Service Inspection and Operation.....	27
6.2.1	Dis-assembly of burner and boiler	27
6.2.2	6.2.3 Air filter	28
6.2.3	Ignition and flame sensing electrodes	28
6.2.3.1	Spark gap adjustment.....	28
6.2.4	Fan.....	28

- 6.2.5 Venturi unit28
- 6.2.6 Gas valve28
- 6.2.7 Electrical circuits.....29
- 6.2.8 Re-assembly of burner and boiler29
 - 6.2.8.1 Gas and electrical connection.....29
 - 6.2.8.2 Turn burner on and final check.....29
- 6.1 Fault Finding30
 - 6.1.1 Abnormal Conditions30
 - 6.1.1.1 Air Pressure Switch Stuck Open.....30
 - 6.1.1.2 Air Pressure Switch Stuck Closed30
 - 6.1.1.3 Flame Signal Check during- Start-up sequence.....30
 - 6.1.1.4 No Flame sensed at the end of the Safety Time, TS.....30
 - 6.1.1.5 Reaction to loss of flame during Burner operation30
 - 6.1.1.6 Supply voltage interruption30
 - 6.1.1.7 Opening of "High limit thermostat"31
 - 6.1.2 Lockouts/Blockings31
 - 6.1.2.1 Lockout / Blocking error codes list.....31
 - 6.1.2.2 Lock-out Reset.....31
 - 6.1.2.3 Remote Reset:.....31
 - 6.1.3 Maintenance Notes.....32

1 Declaration

The Inverterjet burners are state of the art burner system. It utilises the very latest technology to provide a reliable, hot, clean and compact gas heating solution.

A truly market leading product which is;

'Taking Burner Technology into the 21st Century'.

Please read this manual before Unpacking and Installing the Burner.

For Burner Installation/Operation advise please contact Burnertech

To ensure maximum product reliability, we advise and request that a Burnertech Approved Engineer who has attended our product course conducts the 1st burner commissioning.

For Training, Service or Commissioning information please contact Burnertech

This manual is provided as an integral part of the equipment and its delivery to the end user is essential.

Please keep this manual for future reference, more copies of this manual are available upon request. It is possible to download this Manual and Technical Datasheet from the Burnertech Website (www.burnertech.co.uk).

CONTACT / SERVICE:



Unit C Lostock Industrial Estate,
Lostock Lane,
BL6 4BL,
Bolton, United Kingdom.

Tel: +44 (0)1204 393222
Fax: +44 (0)1204 394222
Email: enquiries@burnertech.co.uk
Website: www.burnertech.co.uk

Declaration of conformity

760485



760487

These burners are designed and manufactured in accordance to the **BS EN 676:2020**.

Manufacturer:

Burnertech Combustion Engineers Ltd.

Address:

Unit C, Lostock Industrial Estate

Lostock Lane,

BL6 4BL,

Bolton, United Kingdom

Managing Director
Burnertech Combustion Engineers Ltd.

Mr. David T. Bell

David Bell

24/11/2022

SPECIAL ATTENTION BOXES

The following defined terms are used throughout this manual to bring attention to the presence of hazards of various risk levels, or to important product information



DANGER

DANGER indicates an imminently hazardous situation which if not avoided will result in death or serious injury.



WARNING

WARNING indicates a potentially hazardous situation which if not avoided, could result in death or serious injury.



CAUTION

CAUTION indicates a potentially hazardous situation which if not avoided, could result in minor or moderate injury.

CAUTION

CAUTION used without a safety alert symbol indicates a potentially hazardous situation which, if not avoided, may result in property damage.

NOTICE

NOTICE is used to address practices not related to personal injury

SAFETY INSTRUCTIONS

SAFETY INSTRUCTIONS (or equivalent) signs indicate specific safety related instructions or procedures

NOTE: Contains additional information important to a procedure

2 Technical Information

2.1 Burner Identification and Selection

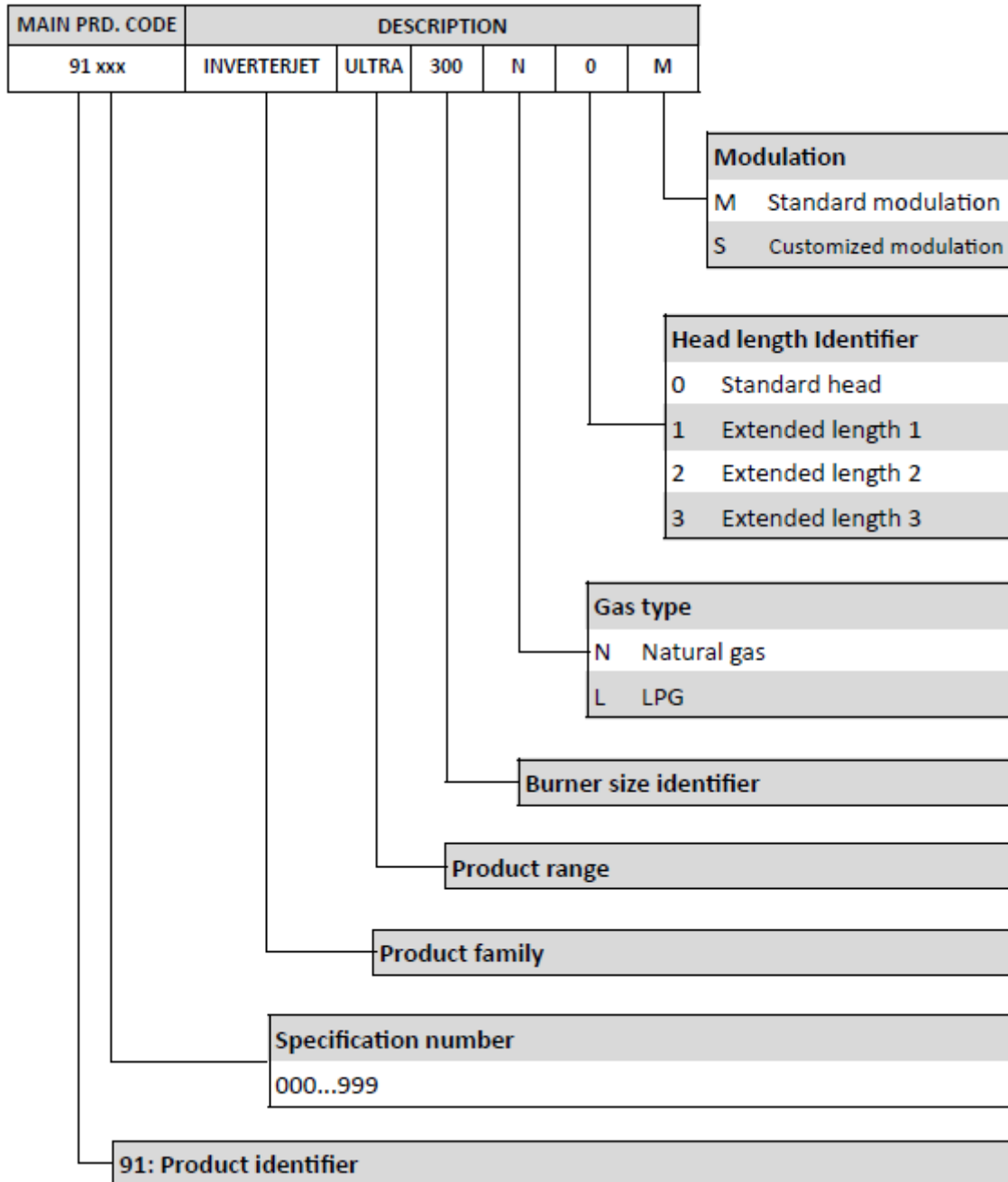

F004

2.2 Burner Identification and Selection

GROUP	GAS	MAIN CODE	PRODUCT CODE	DESCRIPTION	BLAST TUBE LENGTH C [mm]
INVERTERJET ULTRA 120	NG	91413	91413-0	INVERTERJET ULTRA 120N-0-M	122
			91413-1	INVERTERJET ULTRA 120N-1-M	152
			91413-2	INVERTERJET ULTRA 120N-2-M	175
	LPG	91433	91433-0	INVERTERJET ULTRA 120L-0-M	122
			91433-1	INVERTERJET ULTRA 120L-1-M	152
			91433-2	INVERTERJET ULTRA 120L-2-M	175
INVERTERJET ULTRA 150	NG	91415	91415-0	INVERTERJET ULTRA 150N-0-M	122
			91415-1	INVERTERJET ULTRA 150N-1-M	152
			91415-2	INVERTERJET ULTRA 150N-2-M	175
	LPG	91435	91435-0	INVERTERJET ULTRA 150L-0-M	122
			91435-1	INVERTERJET ULTRA 150L-1-M	152
			91435-2	INVERTERJET ULTRA 150L-2-M	175

2.3 Burner dimensions and weight (Pilot: Optional)

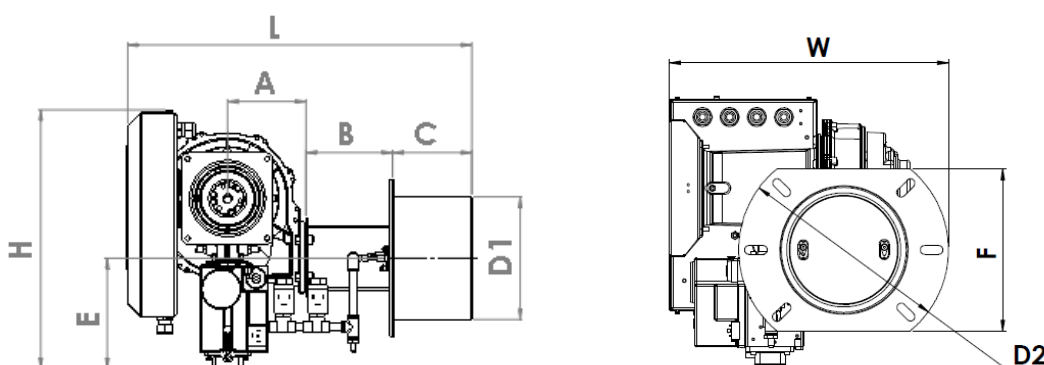

Note: * If fitted (optional), If filter kit is not fitted, use W1 as width of burner

GROUP	MODEL	A	B	C	D1	D2	E	F	H	L	W	Wt.
		mm	mm	mm	mm	mm	mm	mm	mm	mm	mm	kg
Inverterjet Ultra 120	120N-0, 120L-0	122	156	122	Ø188	Ø310	172	240	398	550	415	13
	120N-1, 120L-1			152						580		15.2
	120N-2, 120L-2			175						603		16
Inverterjet Ultra 150	150N-0, 150L-0	122	156	122	Ø188	Ø310	172	240	398	550	415	13
	150N-1, 150L-1			152						580		15.2
	150N-2, 150L-2			175						603		16

2.4 Burner dimensions and weight (No pilot)

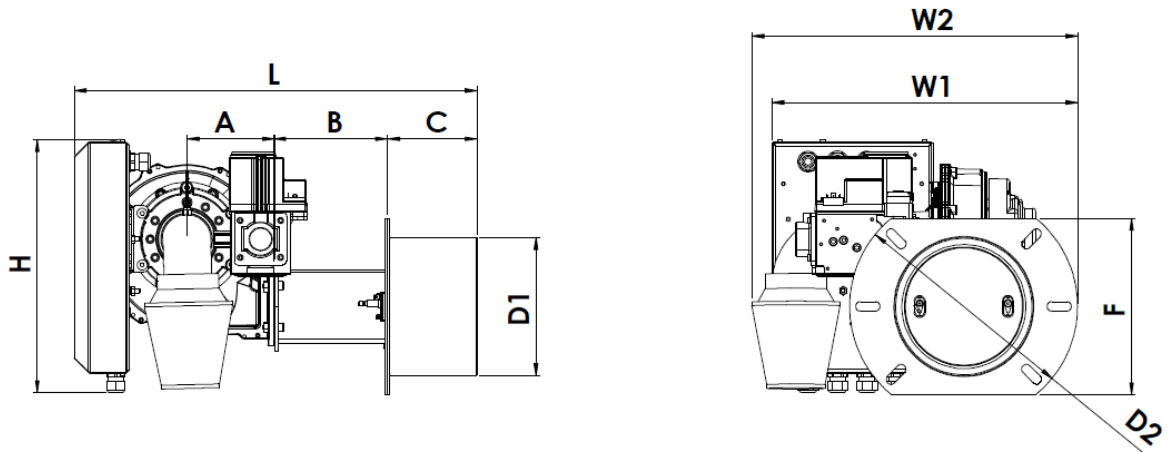

* If fitted (Optional)

Note: If Filter kit is not fitted, use H1 and W1 as height and width of burner

GROUP	MODEL	A	B	C	D1	D2	E	F	H	L	W1	W2*	Wt.
		mm	mm	mm	mm	mm	mm	mm	mm	mm	mm	mm	kg
Inverterjet Ultra 120	120N-0, 120L-0	122	153	122	Ø188	Ø310	117	240	345	550	415	445	12
	120N-1, 120L-1			152									14.2
	120N-2, 120L-2			175									15
Inverterjet Ultra 150	150N-0, 150L-0	122	153	122	Ø188	Ø310	117	240	345	550	415	445	12
	150N-1, 150L-1			152									14.2
	150N-2, 150L-2			175									15

2.5 Firing rate

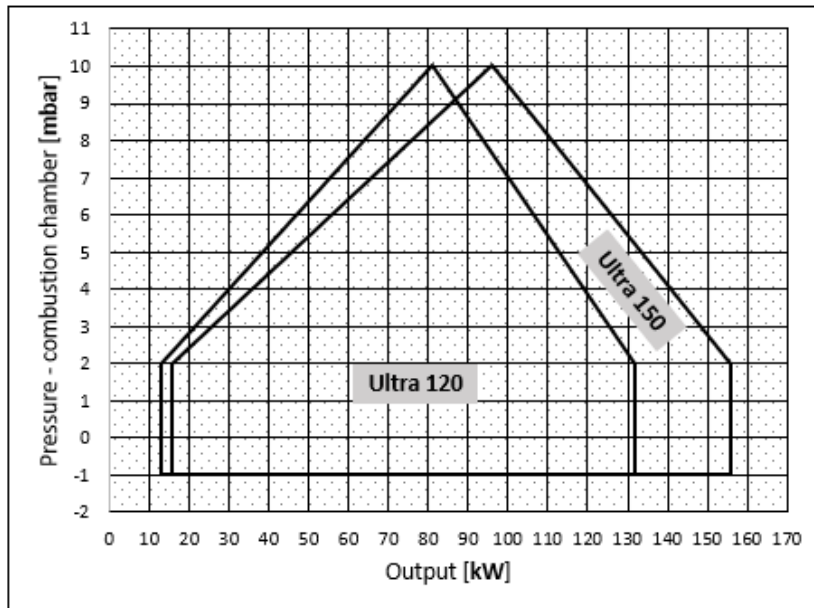

The maximum and minimum outputs are chosen from within the diagram below.

NOTE: The minimum output must not be lower than the minimum limit of the diagram. The burner shall not operate outside the working diagram

2.6 Technical Data

INVERTERJET MODEL			ULTRA 120	ULTRA 150
Type			Pre-Mix Burner	Pre-Mix Burner
Fuel			NG / LPG	NG / LPG
Power	Standard [Max-Min]	kW	132-26.4	156-31.2
	Customized [Max-Min]	kW	132-13.2	156-15.6
Modulation Range	Standard		5:1	5:1
	Customized		10:1	10:1
Nominal Voltage Range		VAC	220..250	220..250
Frequency		Hz	50/60	50/60
Phase			1 ~	1 ~
Fan current draw		A	1.8	1.8
Gas Connection Flange Size			3/4" BSP	3/4" BSP
Gas Inlet Pressure	Min	mbar	10	17
	Max	mbar	50	75
NOx	Max	ppm	19	19
Sound level	Max	dB	68	68

Note: i Customized burners with modulation up to 10:1 are available on request.
 ii Customized outputs depending on requirement on the boiler/heater are available on request.
 iii The current draw is 4.7A if Fasco GPM 7.0H fan is fitted to the burner.

2.7 Description of the Burner Parts (Pilot: optional)

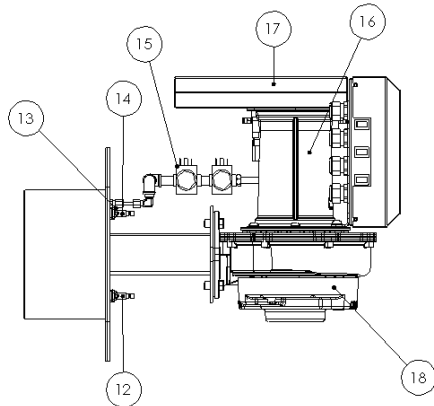
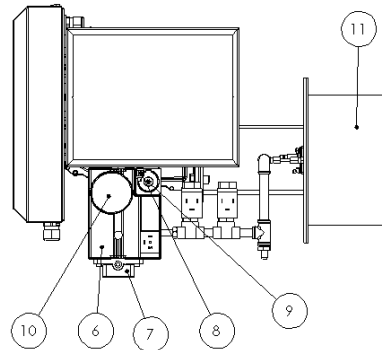
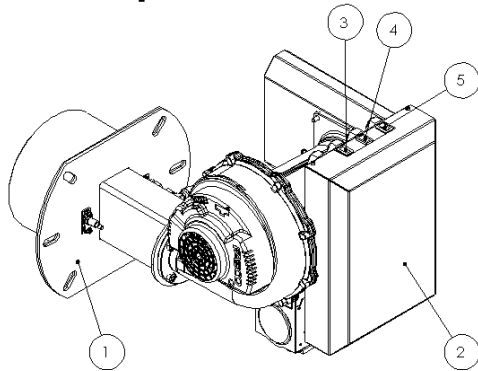

- 1 Burner Mounting Plate
- 2 Burner Management Unit
- 3 Burner On Indicator
- 4 Fault Indicator
- 5 Reset Button
- 6 Gas Valve
- 7 Gas Connection Flange
- 8 Pressure Feedback Connector
- 9 Offset Adjustment Screw
- 10 Throttle Adjustment Screw
- 11 Burner Head **
- 12 Ionisation Probe
- 13 Earth Connector
- 14 Ignition Electrode
- 15 Pilot Gas train *
- 16 Venturi ***
- 17 Filter Kit*
- 18 Fan Housing

* If fitted (Optional)

** 3 different head length configurable, see page 8 above

*** Different shape, alternative fitting on burners with no pilot ignition. see page below

2.8 Technical Description of the Burner Parts (No Pilot)

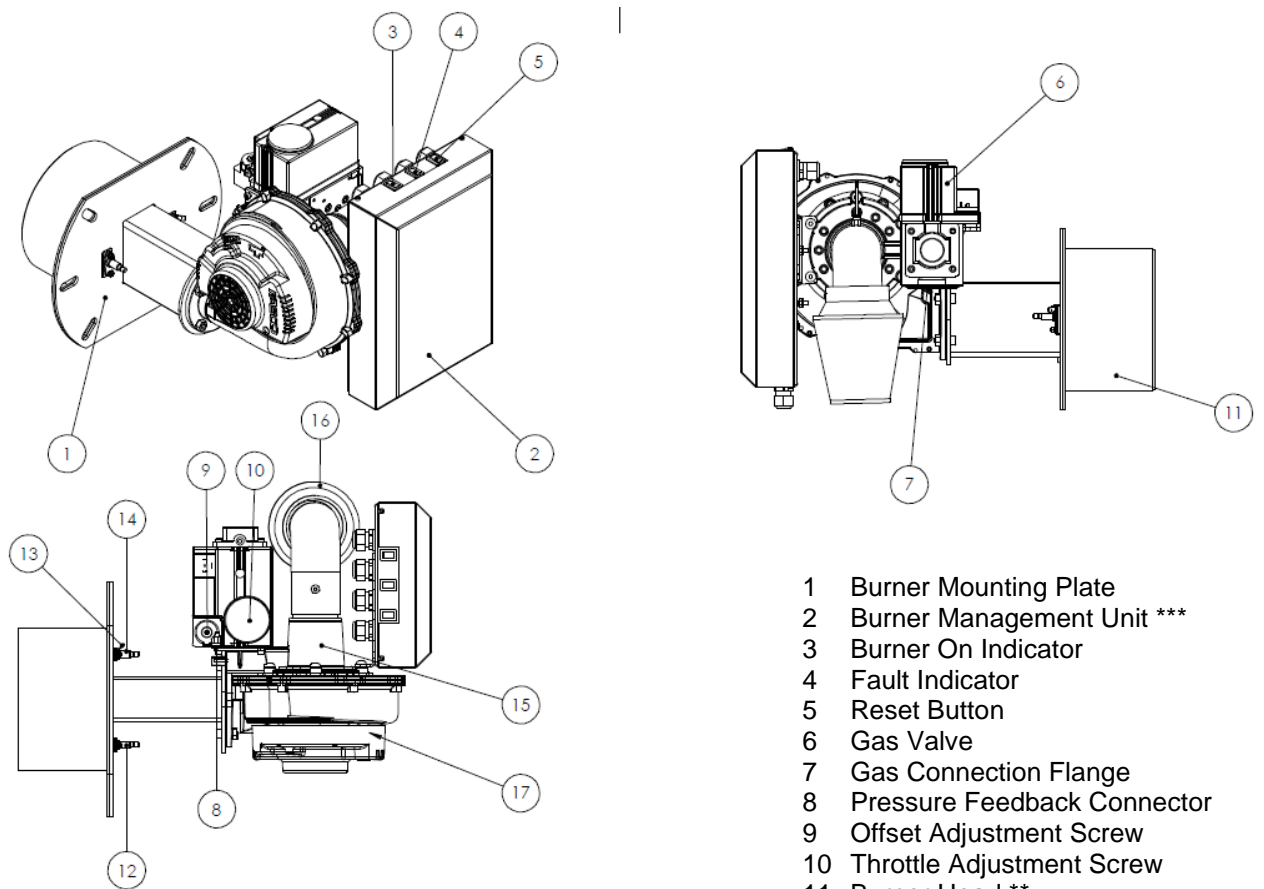

- 1 Burner Mounting Plate
- 2 Burner Management Unit ***
- 3 Burner On Indicator
- 4 Fault Indicator
- 5 Reset Button
- 6 Gas Valve
- 7 Gas Connection Flange
- 8 Pressure Feedback Connector
- 9 Offset Adjustment Screw
- 10 Throttle Adjustment Screw
- 11 Burner Head **
- 12 Ionisation Probe
- 13 Earth Connector
- 14 Ignition Electrode
- 15 Venturi***
- 16 Filter Kit *
- 17 Fan Housing

* If fitted (Optional)

** 3 different head length configurable, see page 8 above

*** Different shape, alternative fitting on burners with pilot ignition. see page above

2.9 Packaging and transportation

The burner is supplied with:

- User manual
- Burner mounting gasket
- Filter kit (Optional)

Note: The burners are carefully packed to minimize damage due to any impact from outside the box. If however the box arrive damaged, contact your supplier for further advice.

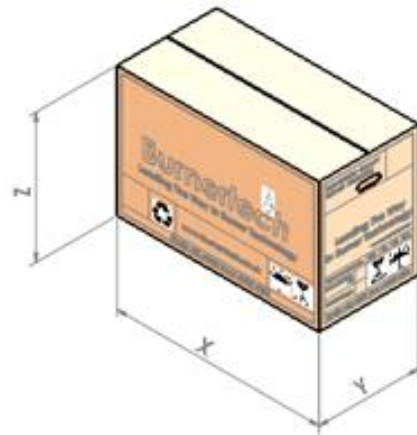

Model	X	Y	Z	Qty. / Box	Weight (Full Box)
	mm	mm	mm		kg
Inverterjet Ultra 120	800	400	550	1	22
Inverterjet Ultra 150	800	400	500	1	22

2.10 Burner operation

2.10.1 Heat demand

Normal heat demand is given by 230VAC switch. The heat demand is validated by 0 – 10V input, via a dedicated relay.

2.10.2 Basic sequence of operation

The table below shows Normal operating sequence for the Burner

	SEQUENCE	DESCRIPTION
Normal Operating Sequence	Stand-by	The igniter is off, the gas valve is closed, and the fan is off. Fan overrun time is finished and continuous fan speed option is switched off.
	Start-up	When a unit in stand-by receives a head demand, the star-up phase is entered.
	Ignition Sequence	The ignition sequence is entered if the start-up phase is completed
	Run position	If the Ignition Sequence is complete, the control energizes the Gas valve and Fan until the head demand is satisfied

2.10.2.1 Stand-by

At power on, the Burner initializes all safety related outputs to be in a predefined and safe state with gas valve de-energized. Then it executes all internal safety checks and stays in Stand-by state waiting for head demand request.

2.10.2.2 Start-up

When a Burner in Stand-by receives a call for heat, the Start-up phase is entered. In this phase the Burner Controller executes a diagnostic check:

- Of the flame signal verifying that there is no parasitic flame signal present
- Of the Air Pressure Switch input (If present). The APS is verified to be in the “no flow” (contact open) position before satisfying a heat request. The fan is not powered unless verification is made and the units proceeds with the ignition phase only if the APS contact closes.

2.10.2.3 Ignition Sequence

The Burner drives the Fan to a predefined speed for a predefined purge time T_p . Following T_p , the pre-spark time begins. This is then followed by the safety time T_s . During this time, the Ignition electrode and the Gas valve are energized.

If the Safety time T_s is complete without a failure, the Burner will be ignited, the Ionisation probe will send signal to the controller and the Burner will remain on. If the Ionisation probe detects no flame, the Burner will return to Start-up sequence. If three Ignition attempts (configurable) is not satisfied, the Burner will lock-out.

2.10.2.4 Run Position

The beginning of the running phase coincides with the final phase of ignition, The fan runs at a fix speed for a pre-defined time(stabilisation time). After the stabilisation time, the modulation is activated. The Burner will remain on until the heat demand disappears.

Once the heat request disappears, the gas valve is de-energized and the Fan remains energized until the post-purge time T_{pp} is passed. Then the control returns to Stand-by. When a heat demand last longer than 24 hours without interruption, the Burner executes a controlled shut-down and the re-start. This procedure lasts a few second(depending on safety time). It is performed to check the correct functionality of the flame sensing circuit.

3 Installation

3.1 General Installation Information



WARNING

The burner **MUST** be installed by competent personnel such as a Gas safe/ACS registered gas installer in compliance with **ALL** current local Regulations, including any National or International Standards that may apply and according to the manufacturer's instructions as detailed in this manual.

CAUTION

The burners are of the pre-mix type and must be installed in a purpose-designed room with sufficient ventilation openings to comply with the current local Regulations, including any National or International Standards that may apply.

Please ensure the opening in the appliance front is large enough to prevent damage to any of the burner parts during fitting.

IF YOU SUSPECT THE BURNER IS DAMAGED, DO NOT USE. You must report any damage to your supplier immediately and seek further advice.

Before connecting the burner, make sure that the burner rating matches the appliance requirements and that both gas and electrical services are adequately rated.

CAUTION

The Maximum operating conditions for the Gas Valve and Electronic Control are 60°C and 90% RH at 40°C non-condensing

SAFETY INSTRUCTIONS

All packing materials should be stored or disposed of with care, as they may prove harmful to children, animals and the environment.

NOTICE

The manufacturer cannot be held liable for injury to people and animals, or damage to property as a result of improper installation.



WARNING

During installation, the burner **MUST** be firmly secured to the appliance using the burner mounting gasket supplied.

The burner **MUST** be connected to an adequately sized gas supply.

The pipe work **MUST** ensure the minimum required dynamic gas supply pressure is achieved when all appliances are operating.

The gas supply **MUST** have an approved isolation valve adjacent to the burner and appropriate means of disconnection for removal of the burner for service and repair.

The electrical supply to the burner **MUST** have a suitable electrical isolation switch. This is required to have a contact separation of at least 3mm in all poles. The burner **MUST** be adequately earthed and installed as required by the current local Safety and Electrical Regulations, and any National or International Standards that apply.

3.2 Handling

Due to the size and weight of the burner, two or more operators are required to handle it during mounting.

3.3 Burner Mounting

To mount the burner, suitable mounting studs or threads for bolts need to be provided for the burner mounting plate. Appropriate dimensions are shown below. When installing the burner, please be sure to use the gasket provided for sealing and insulating between the mounting plate and the bearing wall of the appliance.

3.3.1 Standard Burner Mounting Detail

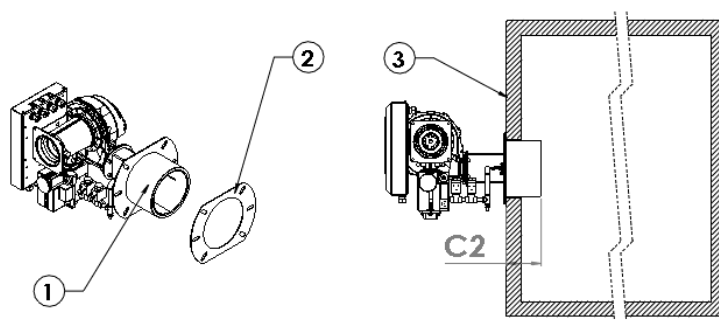
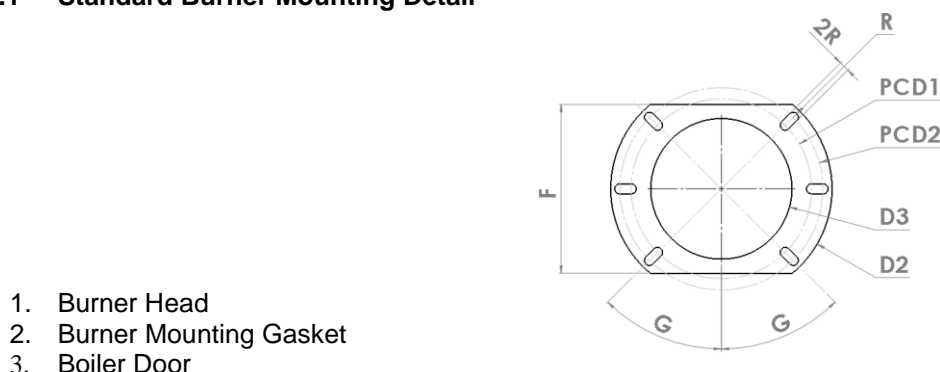

MODEL	C2	D2	D3	F	G	PCD1	PCD2	R	2R
	mm	mm	mm	mm	deg.	mm	mm	mm	mm
Inverterjet Ultra 120x-0	122	Ø 310	Ø 190	240	45°	Ø240	Ø280	6.5	13
Inverterjet Ultra 120x-1	152								
Inverterjet Ultra 120x-2	175								
Inverterjet Ultra 150x-0	122								
Inverterjet Ultra 150x-0	152								
Inverterjet Ultra 150x-0	175								

Note: x = N(NG) or L(LPG), See “2. Burner identification and selection” section above. The penetration C2 above is different depending on the Burner configuration. See Technical Information (Section 2) for all available Burner configurations.

CAUTION

If the appliance is of the ‘Reverse Flame’ type, we strongly recommend that high temperature ceramic insulation is used to back fill between the burner head and appliance door front to prevent overheating around the burner mounting plate. A dedicated mounting plate can be provided upon request.

3.4 Gas Installation

⚠ WARNING

Before commencing the installation, ensure that the gas supply is turned off and that all electrical supplies to the burner are also disconnected.

When connecting a pipe to the Gas Valve inlet always use a sound taper fitting with thread according to ISO 7-1 or a piece of new, properly reamed pipe, free from swarf, dirt or debris.

The burner **MUST** be connected to an adequately sized gas supply. The pipe work must ensure the minimum required dynamic gas supply pressure is achieved when all appliances are operating.

The gas supply **MUST** have an approved isolation valve adjacent to the burner and appropriate means of disconnection for removal of the burner for service and repair.

3.4.1 Gas train

- | | | | |
|-----|-----------------------------|----|---------------------------------|
| 1 | Pressure test point | 6 | Vibration damping joint |
| 2IN | Pressure test point | 7 | Filter |
| OUT | Pressure test point | 8 | Regulation valve |
| 2b | Pilot outlet | 9 | Pilot valves |
| 3a | Interim pressure test point | 10 | Pressure test point |
| 3b | Interim pressure test point | T1 | Responsibility of the installer |
| 4 | Gas Supply line | T2 | Supplied with the burner |
| 5 | Manual shutoff valve | | |

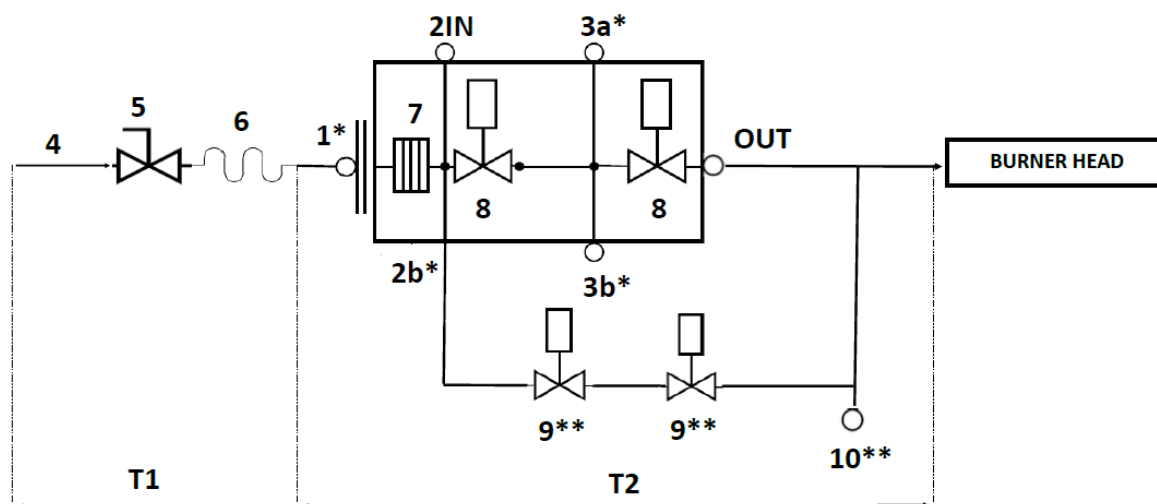

IMPORTANT NOTE

* Available on the Inverterjet Ultra 120-150, 175-400 and 500-800 series only.

** Fitted on all Burner with pilot system only.

To Install the Gas supply to the Burner, follow the instruction below:

1. Remove the seal in front of the gas connection flange at the rear of the burner
2. Check the thread on the flange and ensure that there is no debris in the threads
3. Connect the corresponding gas pipe/fittings(T1) to the gas connection flange.
4. Tighten the gas pipe/fittings and the Gas connection flange securely, ensuring that there is no possibility for gas leakage.

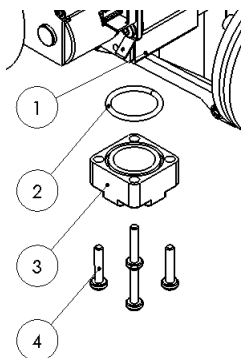

1. Gas valve connection point
2. O - Ring
3. Gas connection flange – 1 “ BSP female
4. Screws
5. 2/2 Manual shut off valve – 1” (see gas train below)

NOTICE

1,2,3 and 4 are supplied with the burner, 5 is the responsibility of the installer.

CAUTION

DO NOT over-tighten gas pipe/ fittings on to the burner as this can cause damage and may affect the gas soundness of the burner.

ALWAYS clean off excess pipe thread cutting oil from gas pipe work before connection to the gas valve. Thread cutting oil will damage the gas valve and will void the warranty supplied with the burner.

ALL gas pipe work installations/ connections to the burner **MUST** be purged and tested for gas soundness by suitably qualified personnel such as a Gas safe/ACS Registered Engineer and **MUST** comply with all Local and National Standards and Regulations before the burner is operated.

3.4.2 Gas leak test

1. Connect a manometer to the gas inlet pressure test nipple on the gas connection flange or the gas valve depending on burner configuration.
2. Pressurize the gas train by turning on the manual shut-off valve and turning it back off.
3. Check if the pressure reading on the manometer is decreasing. Observe for at least 2 minutes.
4. If it is decreasing, tighten adapter screws, joints and pipe connections.
5. Repeat step 2 and 3 above until the pressure reading on the manometer is stable.

3.5 Electrical Installation



WARNING

Suitably qualified and competent personnel must carry out the electrical installation.

Before commencing the installation, ensure that all electrical supplies to the burner are disconnected and that the gas supply is turned **OFF**.

A means of disconnection from the supply having a separation of at least 3mm in all poles **MUST** be provided.

The electrical wiring diagram for the burners is shown in section 3.5.2 below

CAUTION

The burner **MUST** be connected as shown on the burner wiring diagram and **NOT** as shown on any other wiring diagrams.

NOTICE

You **MUST** always comply with the basic safety and electrical regulations that are in force when carrying out the electrical installation of the burner. This includes Statutory Regulations and National and International Standards where they apply.

3.5.1 Basic Electrical Safety



WARNING

Do not allow children or inexperienced people to use the burner.

Do not touch the burner with any wet or damp parts of the body.

Do not pull or strain electrical cables.

Do not leave the burner exposed to the weather unless expressly required to do so.

The burner must be adequately earthed and installed as required by current safety and electrical regulations. Earthing must not be made to any gas carrying components.

Ensure the supply input cable is adequate for the power demand of the burner.

The use of adaptors, multiple outlet or extension cables to connect the burner to the electrical supply is **NOT** permitted.

The burner input cable must not be replaced by the user. In case of damage to the cable, isolate the burner and contact suitably qualified personnel to perform the replacement.

3.5.2 Burner Wiring Diagrams – Inverterjet Ultra 120-150 (With Pilot)

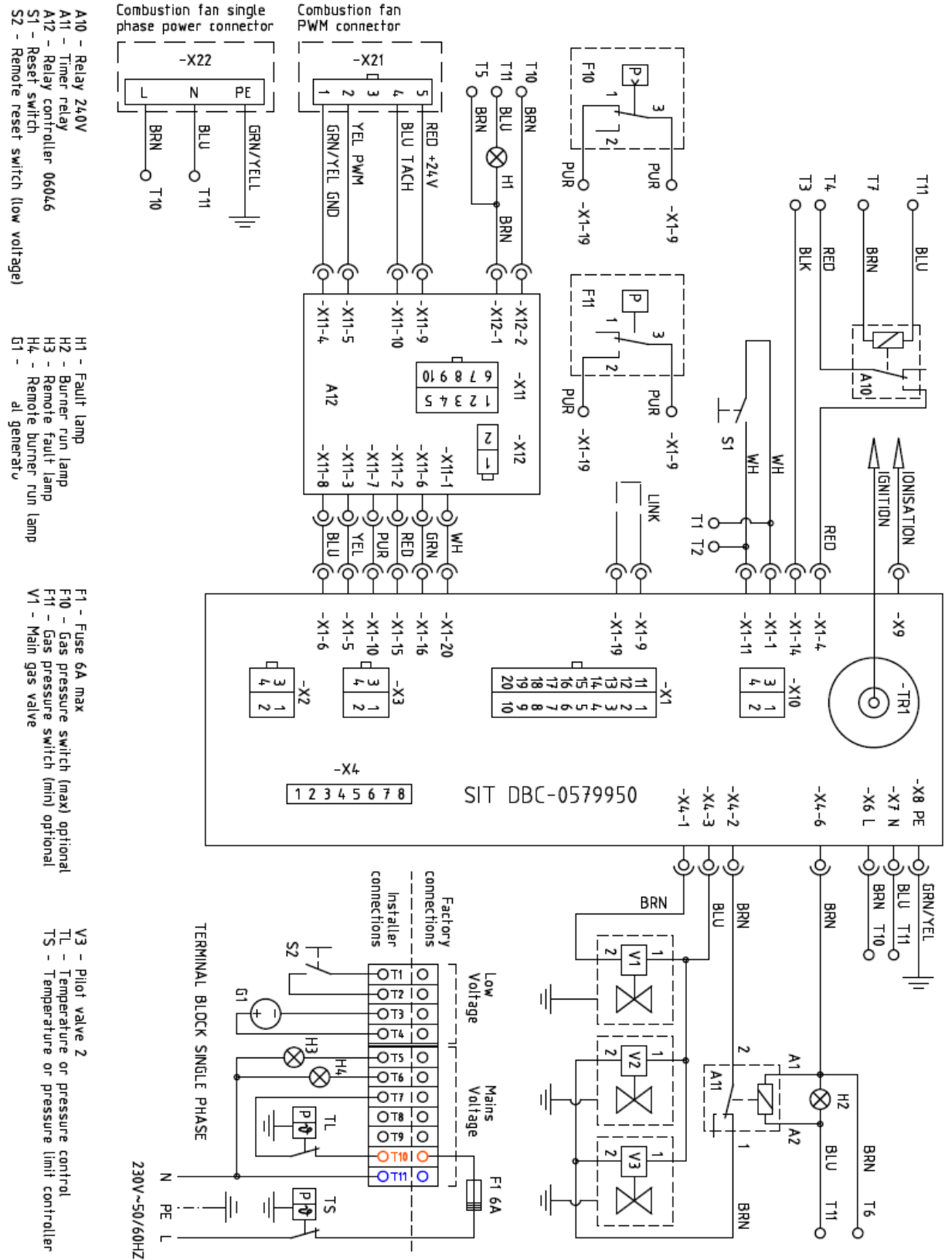

3.5.3 Burner Wiring Diagrams – Inverterjet Ultra 120-150 (No Pilot)

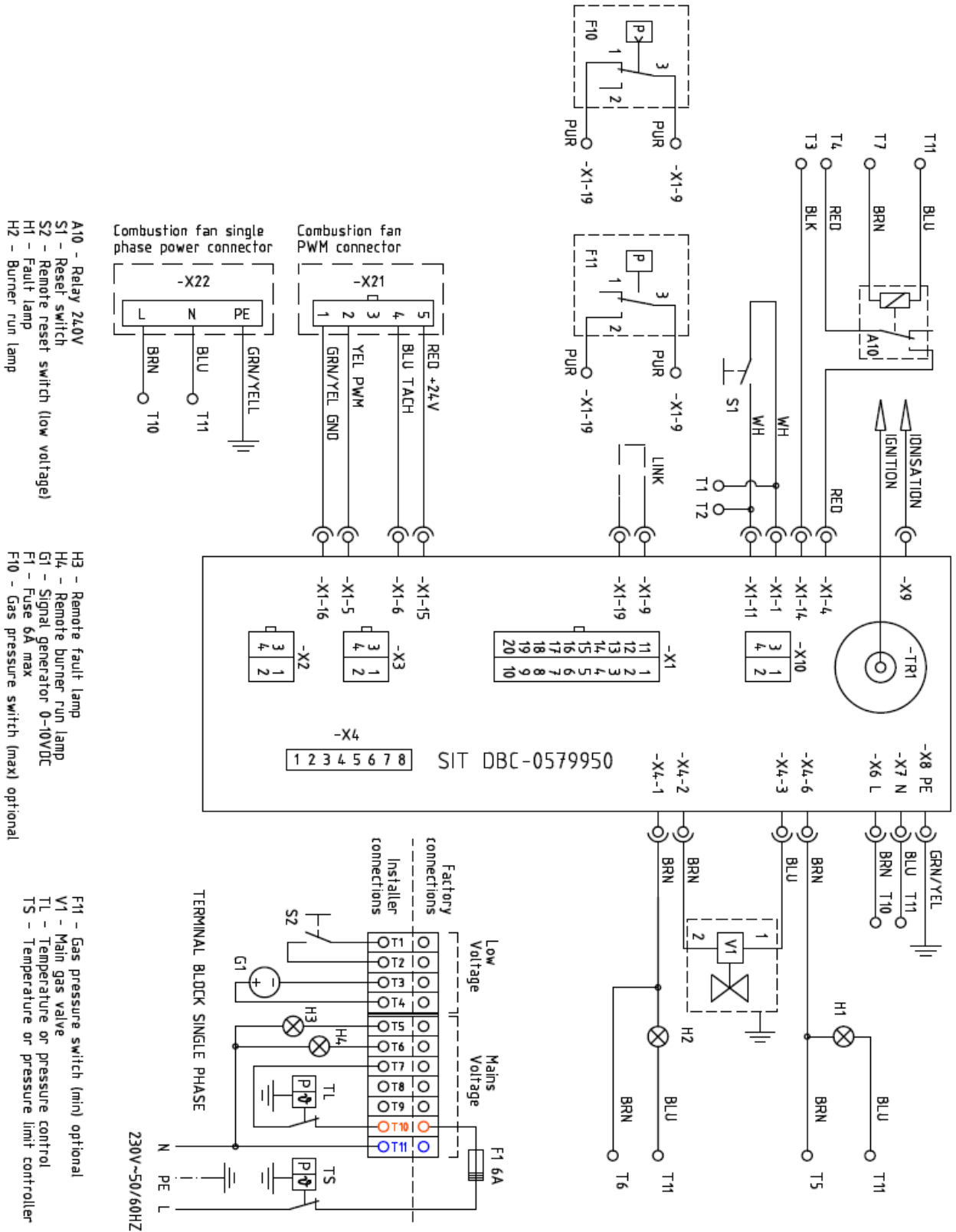

Wiring – Terminal block connection points – single phase

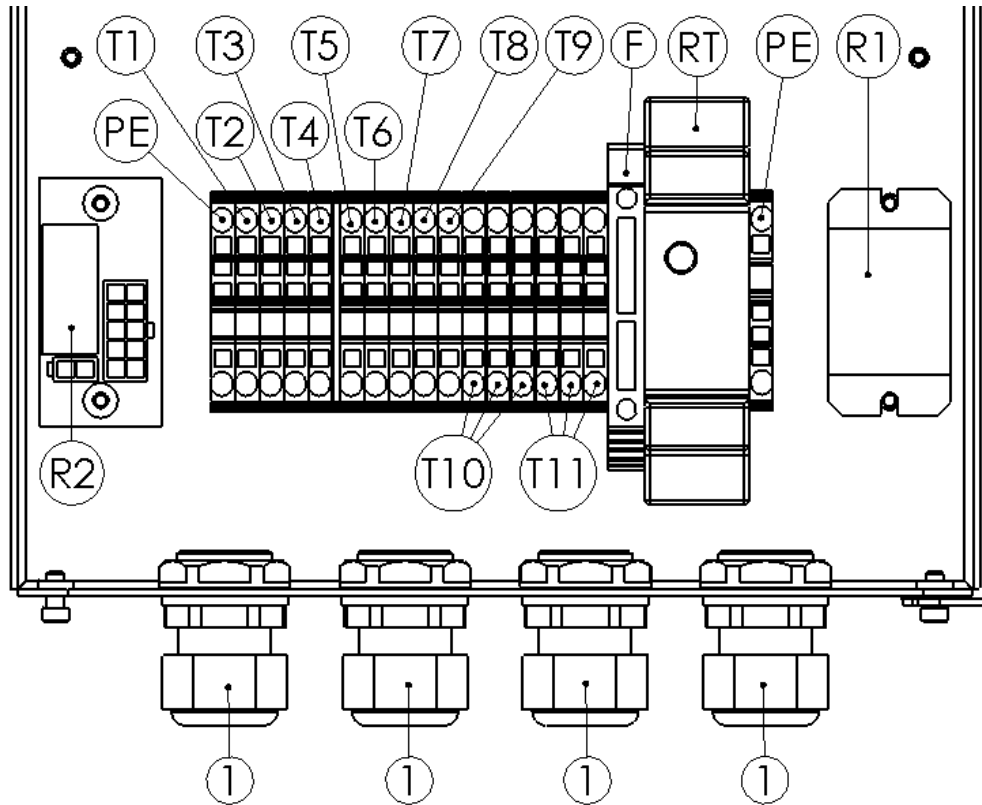

92239

- 1 Available slots for Installer (M20 Cable gland x 4)
- T1 Reset
- T2 Reset
- T3 0 – 10V negative
- T4 0 – 10V positive
- T5 Alarm live
- T6 Burner ON live
- T7 Switched live
- T8 Unallocated (connection points for 3 phase burner only)
- T9 Unallocated (connection points for 3 phase burner only)
- T10 Live (main)
- T11 Neutral
- PE Earth (Permanent)
- R1 R240 Relay
- R2 Relay controller (pilot burner only)
- RT Timer relay (pilot burner only)

Note: The reset, burner ON, alarm, 0-10V and the Main power via quick release plugs outside of the Burner management unit can be fitted and tested at Burnertech. This option is available on request.

4 Commissioning

NOTICE

All Inverterjet premix burners are test fired in the factory prior to despatch to the customer. Whenever possible, Burnertech prefer to pre-set the maximum and minimum fan speed to assist the commissioning process

In order to ensure maximum product reliability, we advise and request that a Burnertech approved engineer conduct the 1st burner commissioning. Failure to comply with this requirement may result to inappropriate burner setting which can lead to damage to property and injuries to personnel.

4.1 Commissioning procedure

To start the commissioning procedure, follow the steps below:

1. Connect a manometer to the gas inlet pressure test nipple on the burner gas inlet connection.
2. Locate CO/CO₂ combustion analyser into flue pipe as close as possible to the appliance outlet.
3. Confirm and record that adequate ventilation is available for the safe operation of the burners.
4. Establish that the system pipe work is complete, fully purged and adequate system load and circulation exists to facilitate firing of the burners.
5. Turn 'On' the gas supply and ensure adequate static gas pressure is available at the burner inlet.
6. Locate the position of the throttle adjustment screw
7. Locate the position of the offset adjustment screw

With Pilot

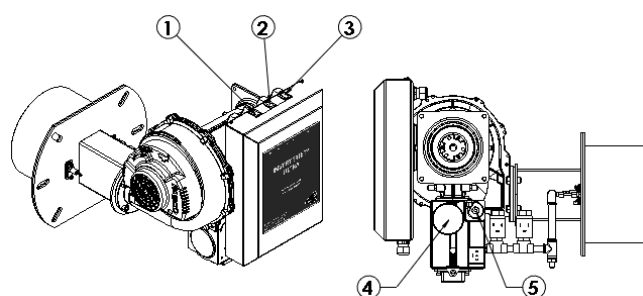

No Pilot

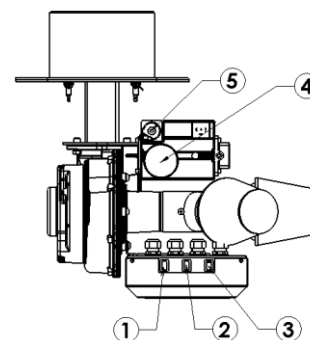

- 1 Burner 'On' Indicator
- 2 Fault Indicator
- 3 Reset Button
- 4 Offset adjustment screw
- 5 Throttle adjustment screw

NOTE: To ensure that the Throttle adjustment screw and the Offset adjustment screw has been correctly identified and also to verify turning direction effects, see the chapter "CO₂ Adjustment Table (Quick Reference)" below.

4.1.1 Turning on the Burner



WARNING

FIRE AND/OR EXPLOSION HAZARD

DO NOT Ignite the Burner until all supply and Installation checks have been made and the test equipment is ready and connected in order to conduct the commissioning procedure.

8. To turn ON the burner, set the 0-10V input to $\geq 1.5V$, turn on the Heat demand switch (230VAC external switch connected to the Burner). The burner fan will start and pre-purge. The burner controller will then drive the fan to a pre-set ignition speed. The ignition spark is generated at this point and the burner will ignite. See "Turn burner ON" section below if necessary

4.1.2 Commissioning operation

NOTE: During the burner commissioning, the maximum and minimum fan speeds can be adjusted if required. The fan speed can be adjusted using the dedicated PC software.

Adjustment of the ignition speed is not recommended as this may affect the reliability of operation and can only be done using the dedicated PC software.

Since the Inverterjet can be used in a multitude of different applications, then the CO₂ should be adjusted to suit the application to which the burner is fitted.

4.1.2.1 Maximum rate CO₂

The maximum CO₂ may be adjusted by use of the throttle screw. The direction to turn the screw varies depending on the Burner. Please see **4.1.2.4 CO₂ Adjustment Table (Quick Reference)** and use the information in the table as a guide to adjust the CO₂ as necessary.

9. Adjust the burner output to high fire by increasing the fan speed
10. Measure the flue CO₂ level and adjust the throttle screw to bring the level to between 9 and 9.5%.

CAUTION

Generally, the CO₂ should not normally exceed 9.5% on NG or 11% on LPG. We recommend that the operating CO₂ is between 0% to +0.5 % higher at maximum fan speed than at minimum.

4.1.2.2 Minimum rate CO₂

Minimum CO₂ should be adjusted using the offset adjustment screw.

Remove the T40 Torx cap (if present) and turn the screw anti-clockwise to decrease the CO₂ and clockwise to increase the CO₂. This adjustment should ideally be made with the use of a micromanometer to help ensure that it is set accurately as this is a sensitive adjustment

11. Adjust the burner output to low fire.
12. adjust the offset adjustment screw (4) to bring the CO₂ level to between 8.5 and 9%.
13. Changing the high fire setting will affect the low setting but changing the low setting will have minimal effect on the high setting. It may therefore be necessary to repeat step 9 to 12 several times in order to achieve the acceptable level of CO₂ at both firing rates.
14. Analyse the flue products on both high and low fire. In both cases, ensure that all readings (CO₂, CO and O₂) are within acceptable figures.

4.1.2.3 Burner Heat Input

15. With an appropriate gas meter, conduct a heat input measurement whilst operating at maximum rate. Ensure the rate is within $\pm 5\%$ of that required for the appliance. If the heat input is outside the required $\pm 5\%$ tolerance, adjust the fan speed until a satisfactory input is achieved.
16. Record all combustion input and working gas pressures and return the burner to normal run condition.

4.1.2.4 CO₂ Adjustment Table (Quick Reference)

Locate the relevant Throttle adjustment screw and Offset adjustment screws by referencing the Venturi/Gas valve with the Burner undergoing commissioning.

Adjust the Throttle and Offset as necessary (see more detail in “Commissioning operation” above).

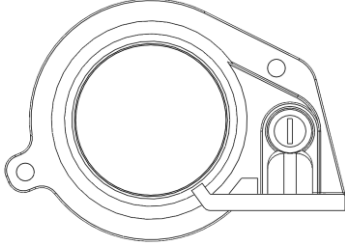
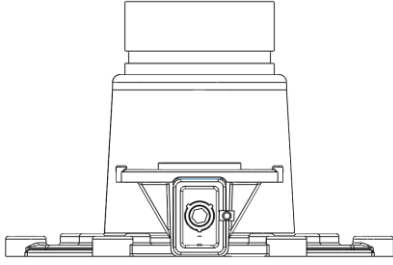
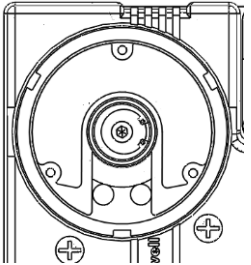
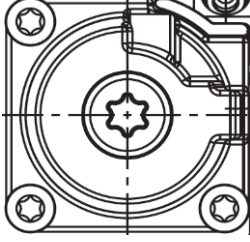
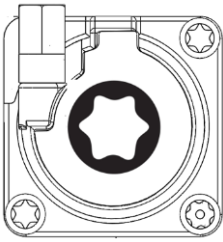
Maximum CO ₂	Throttle Adjustment	Venturi		Gas Valve
		45900 Series	VMS Series (With Throttle)	VR400 Series
		Inverterjet Ultra 30 - 60	Inverterjet Ultra 120 (depending on configuration)	Inverterjet Ultra 120 - 800
				
	Decrease	Turn Clockwise	Turn Anti-Clockwise	Turn Clockwise
Increase	Turn Anti-Clockwise	Turn Clockwise	Turn Anti-Clockwise	
Minimum CO ₂	Offset Adjustment	Gas Valve		
		VK4115 Series	VR400 Series	
		Inverterjet Ultra 30 - 60	Inverterjet Ultra 120 - 800	
				
	Decrease	Turn Anti-Clockwise	Turn Anti-Clockwise	
Increase	Turn Clockwise	Turn Clockwise		

NOTE: To adjust the Maximum CO₂ on the VR400 Series, remove the Throttle Adjustment Screw Cap (Circular Cover) to reveal the Throttle Screw.

CAUTION

The Offset adjustment should ideally be made with the use of a micromanometer to help ensure that it is set accurately as this is a sensitive adjustment.

4.1.2.5 Measured records

After the adjustments above have been made, record the following measured reading. This can be recorded at the maintenance note section in the manual.

- Gas type
- Wobbe index (calorific value)
- Volume gas flow rate
- Minimum and maximum heat output rates
- Supply gas pressure
- Adjustment gas pressure
- CO and CO₂-percentage content of the flue gases (QCO, fCO₂)
- Combustion air temperature
- Flue gas temperature
- NO_x mean emission value QNO_x (Hs)
- Auxiliary electricity consumption: max (elmax) min (elmin), Stand-by (PSB)
- Sound power level LWA

NOTE: The manual is an integral part of the Burner and should be kept close by for quick reference.

4.1.3 Service Mode

The Service mode can be used to control the burner with external communication.

4.1.3.1 PC USB Interface

If required, a windows-based software along with a dedicated USB cable and driver is available to enable programming of certain parameters in the control and also to read fault codes, etc.

NOTE: Please contact Burnertech for more information relating to this option.

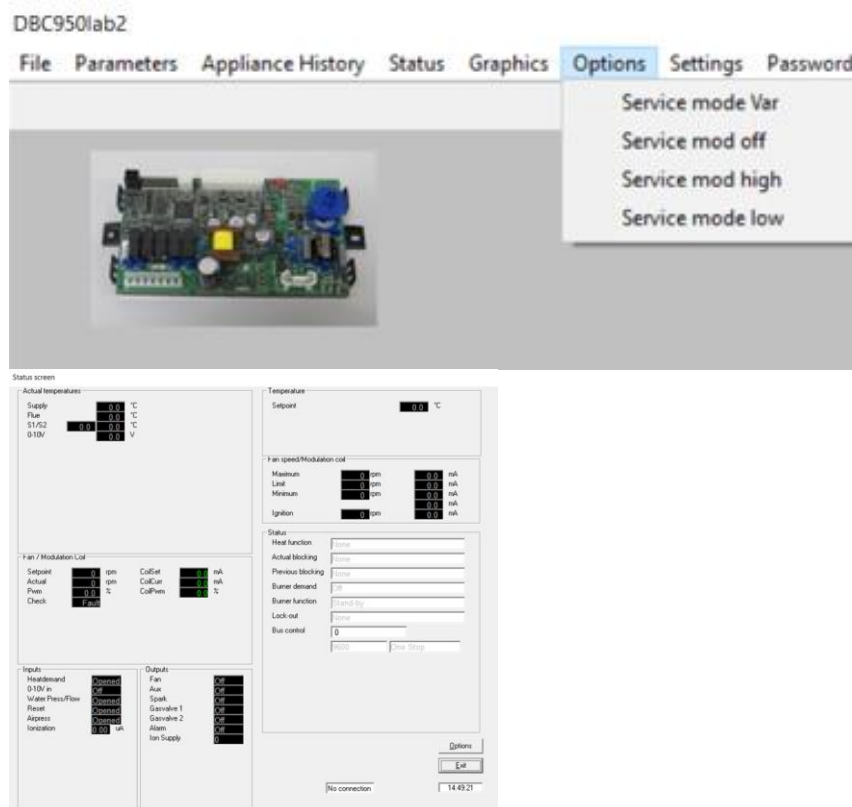

5 User Instructions

5.1 Limitations on use of Burner



CAUTION

The burner **MUST** not be operated before a suitably qualified Burnertech Approved Engineer has conducted a 1st Commissioning. Failure to comply with this requirement may result to improper burner settings which can lead to damage to property and injuries to personnel

The burner **MUST** only be operated when installed into an appliance connected to a suitable flue system. All other uses are improper and therefore dangerous.

The burner **MUST** be electrically connected as described and shown in this manual. The regulating and safety equipment of the burner and associated appliance, which ensure the safe and proper operation of the burner, are of great importance.

CAUTION

Burnertech recommend a 12-month Service Interval for the burner.

If the appliance is of the **Reverse flame** type, we **strongly** recommend that high temperature ceramic insulation is used to back fill between the burner head and door of the appliance.

On-Site' modification of burner components or internal wiring is **strictly forbidden**.

Never dismantle any part of the burner or installation unless professionally qualified to do so. Improper handling can lead to damage of the burner.

The burners are not suitable for dusty process applications without prior modification by Burnertech and/or air filter protection.

DO NOT operate the burner in dusty environments for long periods of time or whilst sweeping the boiler plant room. Dust ingress can cause blocking of the burner combustion head leading to reduced heat input and a significant increase in the chance of premature burner failure.

CAUTION

The Maximum operating conditions for the Gas Valve and Electronic Control are 60°C and 90% RH at 40°C non-condensing

5.2 Using the Burner

5.2.1 Turn Burner On

To switch on the Burner, set the 0-10V input to $\geq 1.5V$, turn on the Heat demand switch (230VAC external switch connected to the Burner). The burner fan will start and pre-purge. The burner controller will then drive the fan to a pre-set ignition speed. The ignition spark is generated at this point and the burner will ignite.

If satisfactory ignition takes place, the burner will remain alight and the fan speed will modulate in response to the modulation signal input.

If satisfactory ignition does not take place, the burner will go through 'Post-purge' and 'Pre-purge' before re-attempting 'Ignition'.

This re-cycle will take place three times (depending on the settings) before the burner will enter a Lock-out condition which will require manual reset by the user by depressing the reset button to restart the burner ignition sequence. See "Burner operation" section above for more details.

NOTE: The maximum number of remote resets in 15 Minutes is five

5.2.2 Turn Burner Off

To switch off the Burner, turn off the Heat demand source. The burner will proceed to standby mode

NOTE: The maximum number of remote resets in 15 Minutes is five

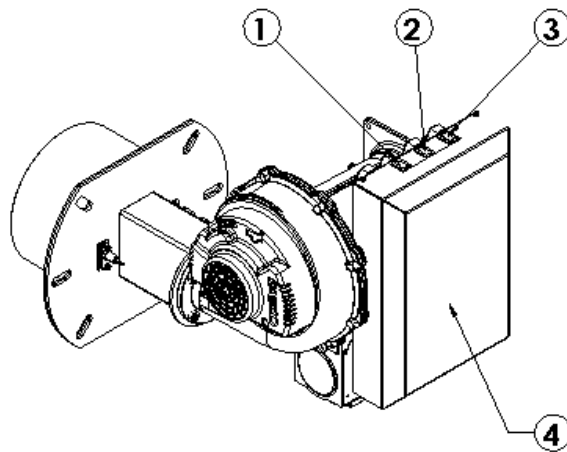

1. Burner "On" indicator
2. Fault indicator
3. Reset button
4. Burner management unit

6 Servicing

NOTICE

We recommend that a Bumertech Approved Engineer, who will have the specific product knowledge and genuine spare parts carry out service and repair operations to ensure continued reliability of the burner system.

6.1 Service Intervals and personnel

A suitably qualified and competent engineer such as a Gas safe/ACS Registered Installer must carry out all the maintenance operations discussed in this section at least once a year.

In the case of seasonal servicing, it is recommended that the service operations be carried out at the end of each heating season.

In the case of continuous operation, the service operations should be carried out every six months.



WARNING

Isolate all gas and electrical supply before carrying out any service or repair on the burner.

6.2 Service Inspection and Operation

6.2.1 Dis-assembly of burner and boiler

NOTE: Before removing the burner from the appliance:

1. Ensure you have a replacement burner mounting gasket for re-fitting the burner afterwards.
2. Prepare an appropriately sized and relatively clean and tidy work area to conduct the maintenance operation.

1. Isolate and disconnect both the gas and electrical supplies from the burner.
2. Supporting the weight of the burner, carefully remove the fixings securing it to the appliance and withdraw it from the chamber.

6.2.2 Burner head

some discolouration of the burner material is normal, but the material should not be cracked or open. The perforated holes in the burner tube beneath the material should not be visible. Inspect the flange of the burner head for any signs of cracking or severe overheating.

CAUTION

Any significant burner head defect would constitute a serious hazard and the burner **SHOULD NOT** be put back into operation until adequately repaired.

If there are signs that there has been over heating of the material or dust on the burner face, the burner head must be removed from the burner. Close examination of the silver foil at the rear of the inside of the burner head should be done. If there is no visible material damage, the inside of the burner head should be blown out using compressed air.

If the inside of the burner head is found to be severely blocked with dust and dirt, It is likely that the material will have overheated due to the blockage and will be blackened in appearance and may need replacing. If so, the customer is advised to protect the burner from dust ingress and/or increase the service intervals.

CAUTION

CAUTION Do not use abrasive brushes on the burner combustion head

6.2.2 6.2.3 Air filter

Check the condition and integrity of the air filter, ensuring that it is not clogged with dust/dirt. If the filter is clogged. It should be replaced.

A clogged air filter will greatly reduce the burner output. The rate at which the filter gets clogged largely depends on the environment it is running. It is advisable to install the burner in a relatively clean environment.

6.2.3 Ignition and flame sensing electrodes

NOTICE

The electrode wires are manufactured from a special metal specifically designed to remove the need for cleaning and withstand very high operating temperatures without movement. However, this special metal can become brittle.

Inspect the ignition and flame electrodes. Check the ceramics are not cracked or damaged and check that the wire is not damaged. If extensive signs of damage are detected, they must then be removed and replaced.

6.2.3.1 Spark gap adjustment

The table below shows the spark gap for optimal ignition.

ELECTRODE TYPE	CONFIGURATION	SPARK GAP [mm]
Double wired electrode	Self – sparking	3.5 ± 1
Single wired electrode	Spark to mat	3.5 - 15

NOTE: If adjustment is required always try and adjust the wires near to the ceramic and preferably using a blowtorch to pre-heat the wire.

6.2.4 Fan

The fan is not a serviceable component. Simply ensure it is positively secured and sealed. The gasket material, electrical plug connections and cover must be secure and in good condition. The fan case has gas tight seals and the fan casing must never be opened. Due to the 1:1 gas/ air ratio operating principle of the burner, a reduction in fan performance (i.e. dust build up) will not result in unsafe burner performance.

The gas flow is directly proportional to the air flow therefore any reduction in fan flow would simply result in a gradual reduction of the appliance heat input.

6.2.5 Venturi unit

Examine and clean the venturi unit checking that it is securely attached, and that any gasket is in good condition. Ensure that any air pressure sensing point is secure and unobstructed (if fitted).

Cleaning: Using a cloth, soft brush and vacuum, carefully remove any dust and grime from the whole burner assembly taking care not to disturb electrical connections.



DANGER

NEVER use water on or around any of the burner electrical connections.

6.2.6 Gas valve

Check the condition and integrity of the gas valve, ensuring that all connections are secure. The gas valve is not a serviceable part. In the unlikely event that a defect is detected, it must be replaced.

6.2.7 Electrical circuits

Check the condition and integrity of the internal burner wiring harness and plugs, ensuring that all connections are secure. Check that both the ignition and probe leads are in good condition.

6.2.8 Re-assembly of burner and boiler

Using a new replacement gasket, carefully and securely slide the burner head up until the gasket and the mounting plate are in contact with the door of the appliance. Refit the burner into with the appliance using the fixings.

6.2.8.1 Gas and electrical connection

Re-connect the gas and electrical connections. Check for gas soundness as detailed in the “**Burner leak test**” section above or as advised by Local, National Standards and Regulations.

6.2.8.2 Turn burner on and final check

Turn ‘ON’ the Gas and Electrical supplies and turn on the burner. See “**Turning on the burner**” section above.

Finally check and record the combustion and ventilation performance of the burner. Check the basic operation/control of appliance before restoring automatic control to any boiler management system (if applicable).

6.1 Fault Finding

6.1.1 Abnormal Conditions

The Burner recognizes the anomalies listed below and reacts as described

	DESCRIPTION
Abnormal Conditions	Air Pressure Switch Stuck Open
	Air Pressure Switch Stuck Closed
	Flame Signal Check during- Start-up sequence
	No Flame sensed at the end of the Safety Time, TS
	Reaction to loss of flame during Burner operation
	Supply voltage interruption
	Opening of "High limit thermostat"

6.1.1.1 Air Pressure Switch Stuck Open

If the APS stays in the "no flow" position after energising the Fan, the burner will not ignite and the gas valve will remain de-energised. If the APS does not go to the expected state within a predefined time (60 seconds) the control proceeds to lockout.

6.1.1.2 Air Pressure Switch Stuck Closed

If the Burner is in stand-by and it receives a heat demand but the APS is already in the "flow" position then the unit remains in stand-by mode with the fan de-energised
If the APS returns to the "no flow" position, the sequence will re-start normally.
If the APS does not go to the expected state within a predefined time (60 seconds) the control proceeds to lockout.

6.1.1.3 Flame Signal Check during- Start-up sequence

If a flame signal is present at the beginning of a start-up sequence, the Burner will not proceed to the next step of the sequence, remaining in a safe condition without energising the Gas valve.
If the flame signal does not disappear with a certain time(configurable), the Burner will proceed to lockout. If the flame sequence disappears before the timeout expires, the start-up sequence will restart normally.

6.1.1.4 No Flame sensed at the end of the Safety Time, TS

If a flame is not established and sensed during the safety time and the number of foreseen trials for ignition is more than a single one, the Burner will enter an inter-purge/inter-waiting time (Tip) phase followed by the pre-purge phase all followed by a new ignition attempt.
In case of an unsuccessful ignition the burner re-tries to ignite multiple times until the flame is not established or as long as the maximum number of attempts to ignite (configurable via parameter 1AJ) is exceeded. If at the end of this process the flame is not established / not sensed the burner will proceed to lockout.
During both inter-purge and pre-purge time the system repeats the parasitic flame check and eventually proceed to lockout in case of flame present. A flame masking time allows to mask the parasitic flame check during inter-purge for a time specified by parameter 1AK.

6.1.1.5 Reaction to loss of flame during Burner operation

In case of flame loss when the unit is in running mode, the unit recycles (it repeats a complete start-up sequence).

The unit will try to ignite multiple times. If the maximum number of re-cycles defined by parameter 1II is reached within the same burner demand the unit proceeds to lockout.

6.1.1.6 Supply voltage interruption

In case of power interruptions the BMU will de-energize the gas valve coil. As soon as the power is restored the burner will be fully operative again.

If the power interruption occurs while the control is in a non-volatile lockout condition, relevant information such as the lockout status and the lockout cause will not be lost.

6.1.1.7 Opening of “High limit thermostat”

The control is provided with an input in series with the gas valve power supply for a High Limit / Overheat cut-off device realized by a mechanical switch. When this safety contact opens the system proceeds to lockout.

A safety dual temperature sensor can also be connected to the control. When the temperature exceeds a pre-defined (but configurable) value the control proceeds to lockout.

6.1.2 Lockouts/Blockings

Error codes / Faults is divided in two groups, Lock-out condition codes and Blocking condition codes. The fan will not operate if there is a lockout or blocking condition.

6.1.2.1 Lockout / Blocking error codes list

A complete list of errors is given in the following table:

NOTE: The Error / Fault codes are visible only through a PC interface

ERROR CODE	DESCRIPTION	VOLATILE/NON VOLATILE
LOCK-OUT ERRORS		
239	F00 ECO 1 water tempera	
192	F02 supply sensor shorted	
193	F02 supply sensor interrupted	
197	F04 Flue sensor shorted	
198	F04 Flue sensor interrupted	
190	F05 Supply maximum	
233	F09 No ignition	
232	F10 Flame fault	
237	F11 False Flame	
230	F13 Fan speed Low	
231	F14 Fan speed High	
236	F15 APS stuck open	
235	F16 APS stuck closed	
189	F17 Flue maximum	
177	F43	
250	Too many resets attempts (6) within 15 minutes	Volatile, not resettable by reset signal, only by power cycle
BLOCKING ERROR		
	Supply temperature	
	Anti-cycling timer	

6.1.2.2 Lock-out Reset

Lockout condition can be cleared by pressing the reset button on the burner management unit. Blocking error will be resolved automatically if the cause of the error disappeared.

6.1.2.3 Remote Reset:

Maximum 5 reset attempts are allowed within 15 minutes from the first reset. If a 6th attempts is done within the 15 minutes then the unit goes in a volatile lockout which can exited only via a power cycle.



CONTACT / SERVICE:



Unit C Lostock Industrial Estate,
Lostock Lane,
BL6 4BL,
Bolton, United Kingdom.

Tel: +44 (0)1204 393222
Fax: +44 (0)1204 394222
Email: enquiries@burnertech.co.uk
Website: www.burnertech.co.uk